

# Dedicated Demolition Line DR-Series



 **DemaPower**  
system

**NEW**

Trendsetter in Demolition and Recycling Equipment



15t 16t 17t 18t 19t 20t 21t 22t ... 25t ... 30t 32t 35t ... 50t ... 65t

**DRC / DRD / DRP Rotating Combi Shear/Demolition Shear/Pulveriser with DemaPower system**

The rotating Demolition Tools of the new Dedicated Demolition Line (DDL) have been developed for primary and secondary demolition. Their Jaws are designed to each application area within a demolition job site: Combi Shear DRC, Demolition Shear DRD or Pulveriser DRP. The patented DemaPower cylinder concept provides up to 20% more power and obviously quicker cycle times.

**Advantages:**

- maximized working speed with the DemaPower cylinder and robust pin suspension, four chamber technique and speed valve
- rotation head with additional oil passage
- twin rotation motors for extra rotation power
- swing bearing double pivoted
- rotation circuit filters
- teeth, shrouds and cutting blades exchangeable
- excellent speed/ power to weight ratio
- DRP: exchangeable ground tooth-plate

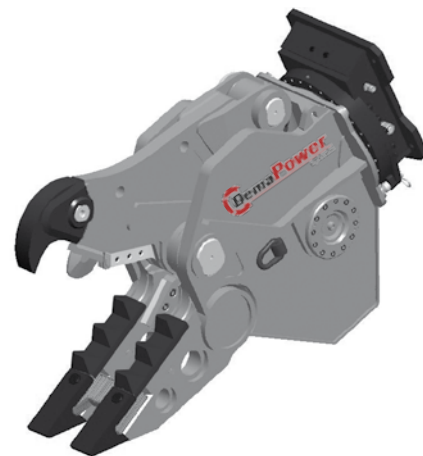

Rotating Combi Shear DRC									
Type	Operating weight excavator (t)	Weight (kg)	Jaw width A (mm)	Width lower jaw B (mm)	Width upper jaw C (mm)	Height D (mm)	Jaw depth E (mm)	Length cutting blades (mm)	Closing force * (kN)
DRC-25	18 - 25	1840	785	390	90	1940	800	400	750 / 1100
DRC-30	22 - 35	2400	875	455	100	2150	900	450	900 / 1400
DRC-45	32 - 50	2950	980	470	100	2370	990	500	1200 / 1700

Rotating Abbruchzange DRD									
Type	Operating weight excavator (t)	Weight (kg)	Jaw width A (mm)	Width lower jaw B (mm)	Width upper jaw C (mm)	Height D (mm)	Jaw depth E (mm)	Length cutting blades (mm)	Closing force * (kN)
DRD-25	18 - 25	1850	825	400	90	1980	800	200	800 / 1300
DRD-30	22 - 35	2400	870	475	100	2155	885	200	950 / 1450
DRD-45	32 - 50	2950	990	525	100	2360	950	200	1200 / 1800

Rotating Pulverisierer DRP									
Type	Operating weight excavator (t)	Weight (kg)	Jaw width A (mm)	Width lower jaw B (mm)	Width upper jaw C (mm)	Height D (mm)	Jaw depth E (mm)	Length cutting blades (mm)	Closing force * (kN)
DRP-25	18 - 25	1850	790	400	325	1980	800	200	750 / 1200
DRP-30	22 - 35	2380	860	475	350	2155	885	200	900 / 1400
DRP-45	32 - 50	2950	985	525	400	2360	950	200	1200 / 1700
DRP-60	45 - 65	4000	1150	565	450	2555	1020	250	1400 / 2000

\* Cutting Force measured at Front Tooth/ Split Tooth

Type	Open/Close		Rotation	
	Pressure max. (bar)	Flow (l/min)	Pressure max. (bar)	Flow (l/min)
DRC-25 / DRD-25 / DRP-25	350	120-200	140	40-60
DRC-30 / DRD-30 / DRP-30	350	150-250	140	40-60
DRC-45 / DRD-45 / DRP-45	350	200-300	140	40-60
DRP-60	350	300-400	140	40-60

**Technical Drawings**

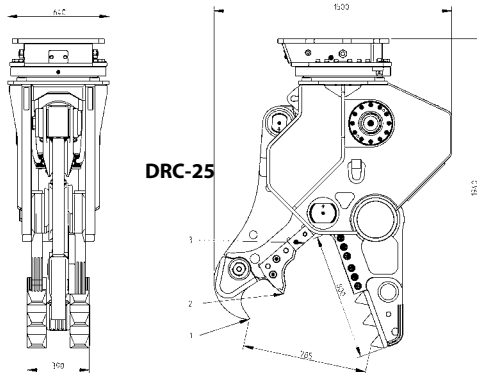

Unique cylinder technics, 20 % more power and extremely fast cycle times

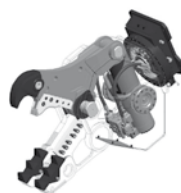

DRC Combi Shear

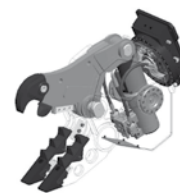

DRD Demolition Shear



DRP Pulveriser

Subject to change without notice.



DDL-DR-03-10-EN

Dealer:

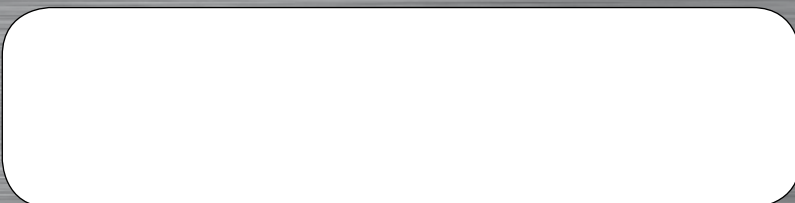

Den Hoek 10      Telefon +31(0)485 442 300  
 5845 EL St. Anthonis (NL)      Telefax +31(0)485 442 120  
 www.demarec.com      info@demarec.com